

Marine Propulsion 3412E Engine

570 kW (764 bhp) 775 mhp @ 2100 rpm

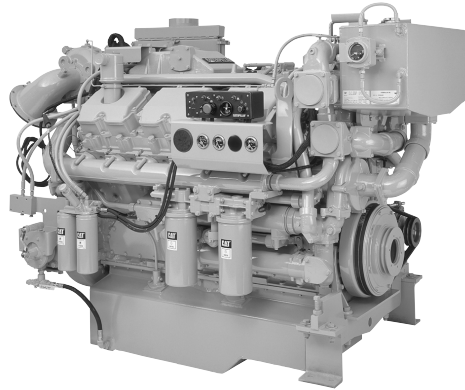

Keel Cooled Arrangement
Shown with Accessory Equipment

STANDARD EQUIPMENT

Air Inlet System

Corrosion resistant aftercooler core, heavy duty panel type air cleaner, air cleaner inlet adapter 254 mm (10 in.)

Cooling System

Gear driven, non-self-priming auxiliary sea water pump with bronze impeller (heat exchanger engines); gear driven, centrifugal jacket water pump, expansion tank (keel engines only); heat exchanger and coolant recovery system (heat exchanger engines); transmission oil cooler; engine oil cooler; thermostats and housing with 92°C (198°F) full open temperature

Exhaust System

Watercooled manifold and turbocharger; dry elbow and flange, 203 mm (8 in.)

Flywheel and Flywheel Housing

SAE No. 0 (136 teeth)

Fuel System

Fuel priming pump; fuel transfer pump; fuel filter — RH service on port, LH service on starboard; Hydraulically actuated Electronically controlled Unit Injector (HEUI) fuel system; flexible fuel lines

Instruments

Instrument panel with start/stop switch; emergency stop button; maintenance lamp; diagnostic lamp; electric service meter; warning lamp; 15A breakers; starter motor magnetic switch; 5-hole panel with oil pressure, water temperature, and fuel pressure gauges

Lube System

Oil level gauge and oil filter — RH service on port, LH service on starboard; crankcase breather; oil filler in valve cover; deep sump oil pan; manual sump pump

Mounting System

Front support

Protection System

Electronic — 24 volt only

General

Vibration damper and guard, Caterpillar yellow paint, lifting eyes, customer wiring connector, service tool connector

SPECIFICATIONS

V-12, 4-Stroke-Cycle-Diesel

Emissions	IMO compliant
Displacement	27 L (1649 cu in.)
Bore	137.2 mm (5.4 in.)
Stroke	152.4 mm (6.0 in.)
Aspiration	Turbocharged-Aftercooled
Governor	Electronic
Engine Weight, Net Dry (approx)	
Heat Exchanger Cooled	2840.7 kg (6257 lb)
Keel Cooled	2769 kg (6105 lb)
Capacity for Liquids	
Cooling System (engine and expansion tank)	72.5 L (19.1 U.S. gal)
Lube Oil System (refill)	138.1 L (36.5 U.S. gal)
Oil Change Interval	400 hr
Caterpillar DEO 10W30 or 15W40	
Rotation (from flywheel end)	Counterclockwise

ACCESSORY EQUIPMENT

- Air Starting Motor
- 24V 35 Amp, 24V 60 Amp Alternator
- Auxiliary Drive Pulley
- Auxiliary Sea Water Pump
- Coolant Level Switch (Keel Cooled Engines)
- Double Wall Oil Line
- Dry Charge Coolant Conditioner
- Duplex Fuel Lines
- Duplex Oil Filters
- 24V Electric Starting Motor
- Engine Monitoring System
- Engine-to-Engine Wiring Harness
- Engine Vision Display System
- Exhaust Elbow, Pipe, Flexible Fittings
- Front Enclosed Clutch
- GPS Interface Module
- Hydraulic Pump Drive
- 8-Hole Instrument Panel
- Marine Power Display
- OEM Wiring Harness
- Pilot House Instrument Panel
- Primary Fuel Filter/Water Separator
- Remote Positive Locking Governor Control
- SAE No. 0 Flywheel
- Sea Water Inlet Connection
- Spare Parts Kit
- Throttle Position Sensor
- Vibration Isolation Mounting

PERFORMANCE CURVES

C Rating — DM6397-00

IMO Compliant

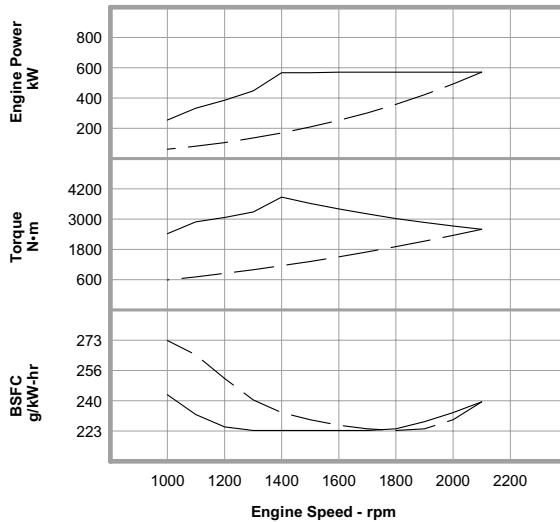

Metric **Maximum Power** ——— **570 kW**
 Prop Demand - - - -

Performance Data

	Engine Speed rpm	Engine Power kW	Engine Torque N-m	BSFC g/kW-hr	Fuel Rate L/hr
Maximum Power Data	2100	570	2592	239.0	162.6
	2000	570	2722	233.0	158.6
	1900	570	2865	228.0	155.2
	1800	570	3024	224.0	152.5
	1700	570	3202	223.0	151.3
	1600	570	3402	223.0	151.4
	1500	568	3617	223.0	151.3
	1400	568	3872	223.0	150.9
	1300	447	3282	223.0	118.7
	1200	385	3066	225.0	103.2
Prop Demand Data	1100	332	2884	232.0	91.7
	1000	254	2427	243.0	73.5
	2100	570	2592	239.0	162.6
	2000	492	2351	229.0	134.2
	1900	422	2122	224.0	112.6
	1800	359	1904	223.0	95.3
	1700	302	1699	224.0	80.7
	1600	252	1505	226.0	67.8
	1500	208	1322	229.0	56.6
	1400	169	1152	233.0	46.8
1300	135	993	240.0	38.7	
1200	106	846	252.0	32.0	
1100	82	711	265.0	25.9	
1000	62	588	273.0	20.0	

Cubic prop demand curve with 3.0 exponent for displacement hulls only.

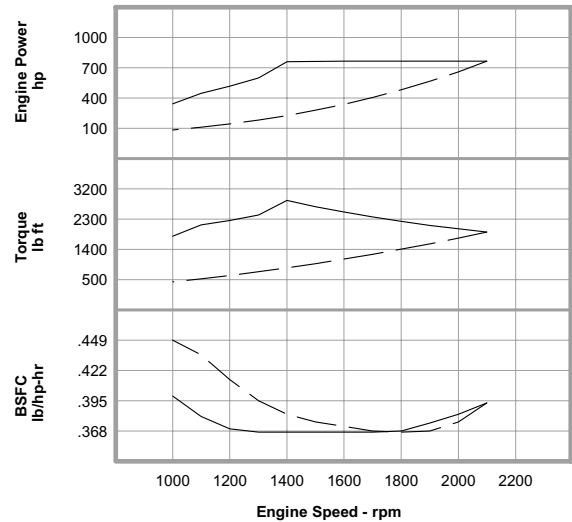

English **Maximum Power** ——— **764 hp**
 Prop Demand - - - -

Performance Data

	Engine Speed rpm	Engine Power hp	Engine Torque lb ft	BSFC lb/hp-hr	Fuel Rate gph
Maximum Power Data	2100	764	1912	.393	43.0
	2000	764	2008	.383	41.9
	1900	764	2113	.375	41.0
	1800	764	2230	.368	40.3
	1700	764	2362	.367	40.0
	1600	764	2509	.367	40.0
	1500	762	2668	.367	40.0
	1400	761	2856	.367	39.9
	1300	599	2421	.367	31.4
	1200	517	2261	.370	27.3
Prop Demand Data	1100	445	2127	.381	24.2
	1000	341	1790	.399	19.4
	2100	764	1912	.393	43.0
	2000	660	1734	.376	35.5
	1900	566	1565	.368	29.7
	1800	481	1404	.367	25.2
	1700	406	1253	.368	21.3
	1600	338	1110	.372	17.9
	1500	279	975	.376	15.0
	1400	226	850	.383	12.4
1300	181	732	.395	10.2	
1200	143	624	.414	8.5	
1100	110	524	.436	6.8	
1000	83	434	.449	5.3	

Power produced at the flywheel will be within standard tolerances up to 50°C (122°F) combustion air temperature measured at the air cleaner inlet, and fuel temperature up to 52°C (125°F) measured at the fuel filter base. Power rated in accordance with NMMA procedure as crankshaft power. Reduce crankshaft power by 3% for propeller shaft power.

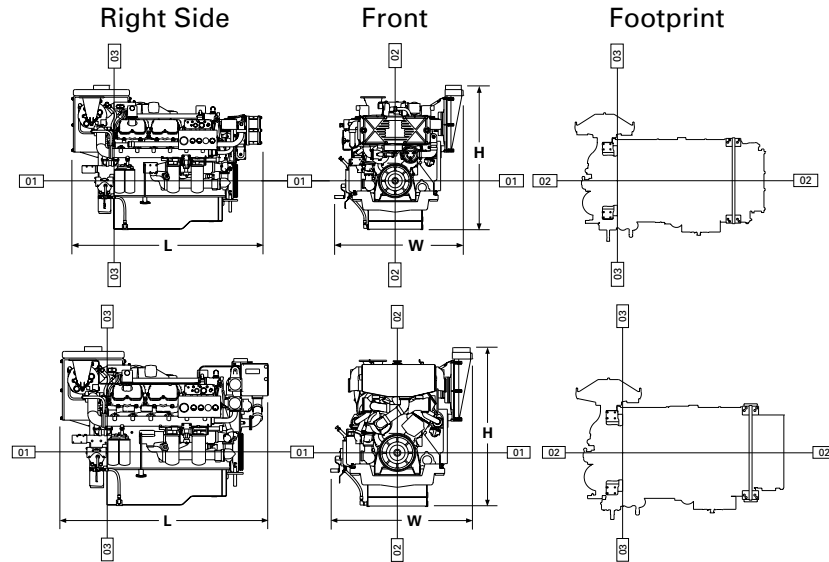

DIMENSIONS*

	Heat Exchanger Cooled		Keel Cooled	
	mm	in.	mm	in.
Overall Length				
Length from front to rear face of block	2137.2	84.1	2119.7	83.5
	1660.7	65.4	1643.2	64.7
Overall Height				
Height from crankshaft centerline to top of engine	1621.4	63.8	1621.4	63.8
Height from crankshaft centerline to bottom of oil pan	1072.9	42.2	1072.9	42.2
	548.5	21.6	548.5	21.6
Overall Width				
Width from crankshaft centerline to port side (left side)	1444.3	56.9	1444.3	56.9
Width from crankshaft centerline to starboard side (right side)	764.0	30.1	764.0	30.1
	680.3	26.8	680.3	26.8
(Heat Exchanger and Keel Cooled arrangements)				
	Front		Rear	
	mm	in.	mm	in.
Customer mounting hole diameter	20.5	0.8		5/8
Width from crankshaft centerline to side	431.8	17.0	352.7	13.9
	457.2	18.0	413.0	16.3
Length from rear face of block to front	1242.5	48.9	78.3	3.1
	1261.5	49.7	154.6	60.6
	1350.5	53.2		
	1369.5	53.9		

*Illustrations and dimensions from drawings: 183-1405 Heat Exchanger Cooled, 183-2012 Keel Cooled.

RATING DEFINITIONS AND CONDITIONS

C Rating –

Typical Application Vessels such as ferries, harbor tugs, fishing boats moving at higher speeds out and back (e.g. lobster, crayfish, and tuna), offshore service boats, and also displacement hull yachts and short trip coastal freighters where engine load and speed are cyclical.

- Typical Hours Per Year 2000 to 4000
- Time at Rated Speed Up to 50%
- Load Factor 20 to 80%
- Typical Time at Full Load 6 out of 12 hours
- Rated Speed 2100 rpm
- Maximum Cruise Speed 2000 rpm
- Maximum Continuous Cruise Speed 1900 rpm

Engine Performance Parameters

- Power ±3%
- Specific Fuel Consumption ±3%
- Fuel Rate ±5%

Ratings are based on SAE J1228/ISO8665 standard conditions of 100 kPa (29.61 in. Hg), 25°C (77°F), and 30% relative humidity. These ratings also apply at ISO3046/1, DIN6271/3, and BS5514 conditions of 100 kPa (29.61 in. Hg), 27°C (81°F), and 60% relative humidity.

Fuel rates are based on fuel oil of 35° API [16°C (60°F)] gravity having an LHV of 42 780 kJ/kg (18,390 Btu/lb) when used at 29°C (85°F) and weighing 838.9 g/L (7.001 lb/U.S. gal).

Additional ratings may be available for specific customer requirements. Consult your Caterpillar representative for additional information.



3412E MARINE PROPULSION — 570 bkW (764 bhp)

Performance data is calculated in accordance with tolerances and conditions stated in this specification sheet and is only intended for purposes of comparison with other manufacturers' engines. Actual engine performance may vary according to the particular application of the engine and operating conditions beyond Caterpillar's control.

TMI Reference No.: DM6397-00 (6-19-01)

Materials and specifications are subject to change without notice.

The International System of Units (SI) is used in this publication.

LEHM1519-01 (5-02)

Printed in U.S.A.

©2002 Caterpillar
All rights reserved.