

Image is a representation only, and may not show optional attachments.

SPECIFICATIONS

I-6, 4-Stroke-Cycle-Diesel

Emissions	IMO compliant
Displacement	12.0 L (732.24 cu. in.)
Rated Engine Speed	2300
Bore	130 mm (5.1 in.)
Stroke	150 mm (5.9 in.)
Aspiration	Turbocharged-Aftercooled
Governor	Electronic
Cooling System	Heat Exchanger
Weight, Net Dry (approx)	1,174 kg (2,588 lb)
Refill Capacity	
Cooling System	45 L (12.0 U.S. gal)
Lube Oil System	28 L (7.5 U. S. gal)
Oil Change Interval	250 hr
Caterpillar Diesel Engine Oil 10W30 or 15W40	
Center Sump Oil Pan	
Rotation (from flywheel end)	Counterclockwise
Flywheel and flywheel housing	SAE No. 1
Flywheel Teeth	113

STANDARD ENGINE EQUIPMENT

Air Inlet System

Corrosion resistant sea water aftercooler, air cleaner/fumes disposal system (closed)

Cooling System

Self-priming gear-driven sea water pump with rubber impeller, gear-driven jacket water pump, integral heat exchanger/expansion tank with removable tube bundle and replaceable copper-nickel tubes, thermostat and housing

Exhaust System

Watercooled exhaust manifold and turbocharger, round flanged outlet

Fuel System

Fuel priming pump, fuel transfer pump, fuel filter — RH or LH service, flexible fuel lines

Instrumentation

Electric service meter

Lube System

Crankcase breather, engine oil cooler; oil filter — RH or LH service, oil level gauge — RH or LH service, oil filler, center sump oil pan, gear driven oil pump

Mounting System

Front support

Power Takeoffs

11 tooth spline SAE A hydraulic pump drive, single groove crankshaft pulley

Protection System

12 or 24 volt electronic shutdown (energized-to-run)

General

Vibration damper and guard, Caterpillar® yellow paint, lifting eyes, variable engine wiring, customer wiring connector and service tool connector

ISO Certification

Factory-designed systems built at Caterpillar ISO9001:2000 certified facilities

MARINE ENGINE PERFORMANCE

C12 DITA
526 kW (705 hp) @ 2300 rpm
E Rating (High Performance) — DM7676-00

IMO Compliant

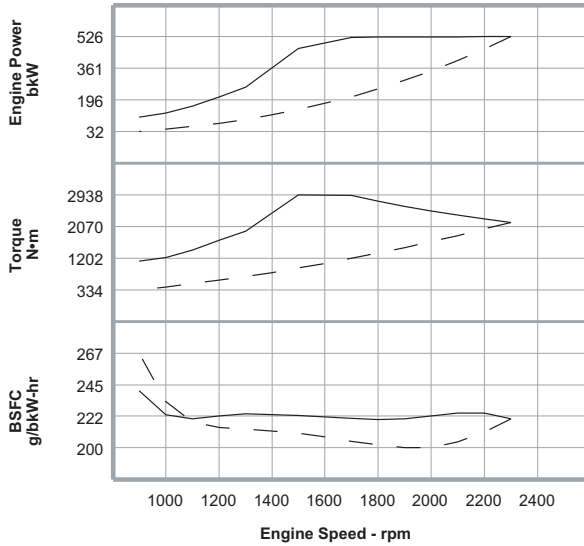

Metric Maximum Power Prop Demand 526 kW

Preliminary Performance Data

	Engine Speed rpm	Engine Power kW	Engine Torque N·m	BSFC g/bkW-hr	Fuel Rate L/hr
Maximum Power Data	2300	526.0	2184	220.2	138.1
	2200	525.0	2279	224.9	140.7
	2100	523.1	2378	224.5	140.0
	2000	522.0	2493	222.3	138.3
	1900	522.0	2624	220.4	137.1
	1700	521.1	2927	220.8	137.1
	1500	461.5	2938	222.7	122.5
	1300	263.8	1938	223.9	70.4
	1200	211.4	1683	222.2	56.0
	1000	128.3	1225	223.3	34.1
900	105.5	1120	240.5	30.3	
Prop Demand Data	2300	526.0	2184	220.2	138.1
	2200	460.3	1998	210.9	115.7
	2100	400.4	1821	204.0	97.4
	1900	296.5	1490	200.0	70.7
	1800	252.1	1338	202.0	60.7
	1600	177.1	1057	207.7	43.8
	1500	145.9	929	210.4	36.6
	1300	95.0	698	213.0	24.1
	1200	74.7	594	214.2	19.1
	1000	43.2	413	232.9	12.0
900	31.5	334	266.8	10.0	

Cubic prop demand curve with 3.0 exponent for displacement hulls only.

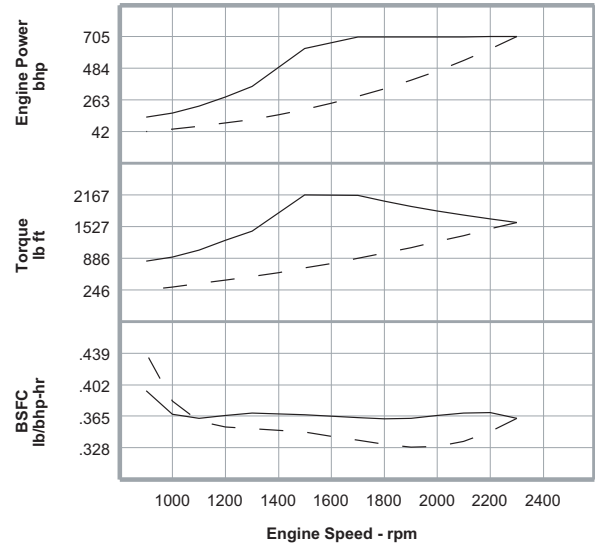

English Maximum Power Prop Demand 705 bhp

Preliminary Performance Data

	Engine Speed rpm	Engine Power bhp	Engine Torque lb ft	BSFC lb/bhp-hr	Fuel Rate gph
Maximum Power Data	2300	705.4	1611	.362	36.5
	2200	704.0	1681	.370	37.2
	2100	701.5	1754	.369	37.0
	2000	700.0	1839	.365	36.5
	1900	700.0	1935	.362	36.2
	1700	698.8	2159	.363	36.2
	1500	618.9	2167	.366	32.4
	1300	353.8	1429	.368	18.6
	1200	283.5	1241	.365	14.8
	1000	172.1	903	.367	9.0
900	141.5	826	.395	8.0	
Prop Demand Data	2300	705.4	1611	.362	36.5
	2200	617.3	1474	.347	30.6
	2100	536.9	1343	.335	25.7
	1900	397.6	1099	.329	18.7
	1800	338.1	987	.332	16.0
	1600	237.5	780	.341	11.6
	1500	195.7	685	.346	9.7
	1300	127.4	515	.350	6.4
	1200	100.2	438	.352	5.0
	1000	57.9	305	.383	3.2
900	42.2	246	.439	2.6	

Power produced at the flywheel will be within standard tolerances up to 50°C (122°F) combustion air temperature measured at the air cleaner inlet, and fuel temperature up to 52°C (125°F) measured at the fuel filter base. Power rated in accordance with NMMA procedure as crankshaft power. Reduce crankshaft power by 3% for propeller shaft power.

DIMENSIONS

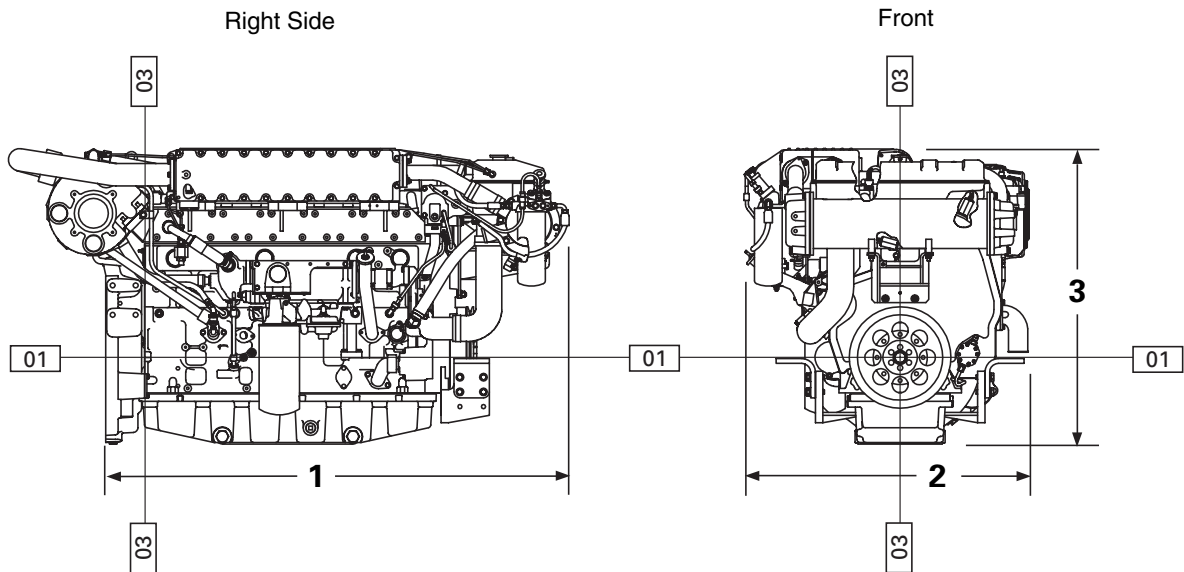

Engine Dimensions		
(1) Length to Flywheel Housing	1573.9 mm	61.96 in
(2) Width	968.6 mm	38.13 in
(3) Height	1008.7 mm	39.71 in
Weight, Net Dry (approx)	1174 kg	2,588 lb

Note: Do not use for installation design. See general dimension drawing for detail (Drawing # 2169705).

RATING DEFINITIONS AND CONDITIONS

E Rating (High Performance)

% Load Factor: up to 30

% Time at Rated RPM: up to 8

Typical Time at Full Load: 1/2 hours out of 6

Typical Hour/Year: 250 to 1000

Typical Applications: For vessels operating at rated load and rated speed up to 8% of the time (up to 30% load factor). Typical applications could include but are not limited to vessels such as pleasure craft, harbor patrol boats, harbor master boats, some fishing or patrol boats. Typical operation ranges from 250 to 1000 hours per year.

Power at declared engine speed is in accordance with ISO3046-1:2002E. Caterpillar maintains ISO9001:1994/QS-9000 approved engine test facilities to assure accurate calibration of test equipment. Electronically controlled engines are set at the factory at the advertised power corrected to standard ambient conditions. The published fuel consumption rates are in accordance with ISO3046-1.

Fuel rates are based on fuel oil of 35° API [16°C (60°F)] gravity having an LHV of 42 780 kJ/kg (18,390 Btu/lb) when used at 29°C (85°F) and weighing 838.9 g/L (7.001 lb/U.S. gal). Additional ratings may be available for specific customer requirements. Consult your Caterpillar representative for additional information.

Performance data is calculated in accordance with tolerances and conditions stated in this specification sheet and is only intended for purposes of comparison with other manufacturers' engines. Actual engine performance may vary according to the particular application of the engine and operating conditions beyond Caterpillar's control.

Power produced at the flywheel will be within standard tolerances up to 50°C (122°F) combustion air temperature measured at the air cleaner inlet, and fuel temperature up to 52°C (125°F) measured at the fuel filter base. Power rated in accordance with NMMA procedure as crankshaft power. Reduce crankshaft power by 3% for propeller shaft power.

CAT, CATERPILLAR, their respective logos and "Caterpillar Yellow," as well as corporate and product identity used herein, are trademarks of Caterpillar and may not be used without permission.